

## Parallel Dual Battery Installation

On dual batteries vehicles only one *PriorityStart!* unit is required, the P/S can handle 1000 cranking amps (**cranking amps are starter amps**). First step is to *firmly* install the U-clip by itself to negative post on battery one. Next the red cable on P/S attached to positive post on battery one.

Attach the terminal connector end of the starter cable to the top of the PS (this attachment is critical, and must be done tightly to maintain good continuity).

**VERY IMPORTANT TO FOLLOW THIS NOTE:** Accessories would connect the same way they were. Remember the PS is now monitoring everything through the cable and so would pick up everything attached down line.

Final step is to connect black ground wire from P/S to U-clip on negative post on battery one.

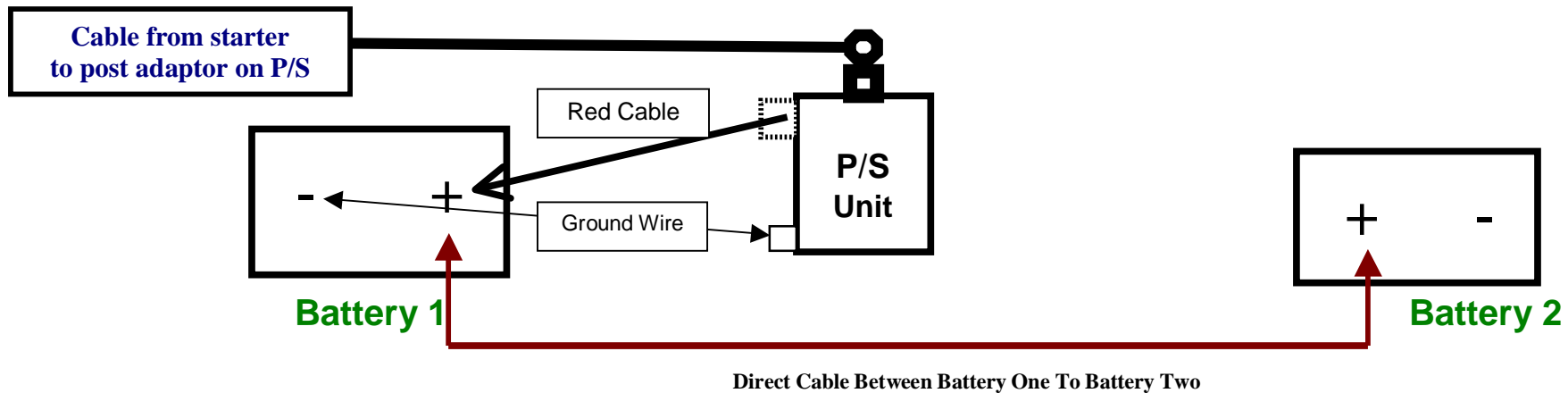

If the batteries are parallel i.e.. 2 - 12 volt batteries positive to positive, and negative to negative you use a 12 volt unit. They are working as one battery.