

ENERGIZER EPX76

SILVER OXIDE

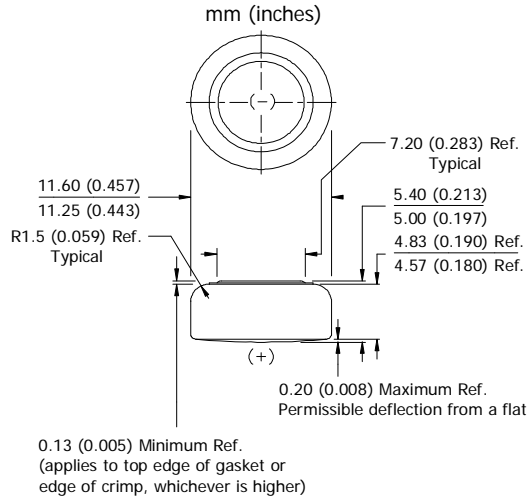

Industry Standard Dimensions



DESIGNED SPECIFICALLY FOR PHOTO USE

Specifications

- Chemical System:** Silver Oxide (Zn/Ag₂O)
- Designation:** ANSI-1107SO, IEC-SR44
- Nominal Voltage:** 1.55 Volts
- Typical Capacity:** 200 mAh* (to 0.9 volts)
- Capacity Test:** 6.5K ohm continuous drain at 21°C
- Typical Weight:** 2.3 grams (0.08 oz.)
- Typical Volume:** 0.57 cubic centimeters (0.035 cubic inch)
- Impedance (40 Hz):** 5 to 15 ohms

* Varies according to the applied load, temperature, and cutoff voltage.

Cross Section

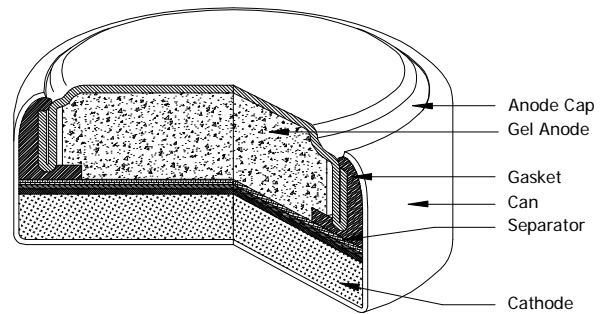

Typical Discharge Characteristics

Typical Performance at 21°C (70°F)

Schedule: Continuous
Typical Drain @ 1.55V:
0.238 milliamperes
Load: 6.5K ohm

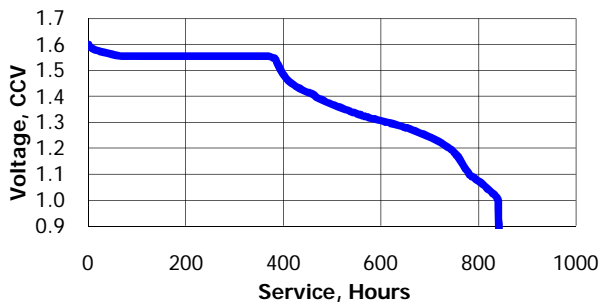

<u>Schedule</u>	<u>Typical Drains</u> at 1.55V (milliamperes)	<u>Load</u> (ohm)	<u>Cutoff</u> 0.9V (hours)
Continuous	0.238	6.5K	840

Temperature Characteristics

Typical Performance at Low Discharge Rates

Service Effects

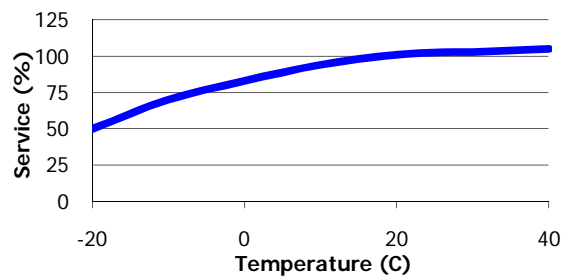

Storage Effects

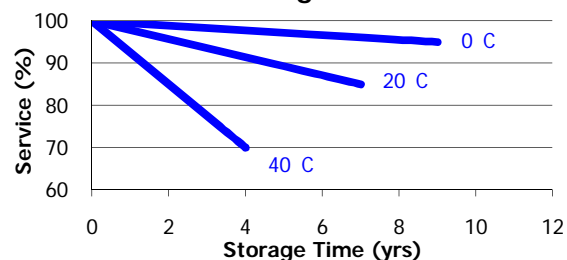

Important Notice

This datasheet contains typical information specific to products manufactured at the time of its publication.

©Energizer Holdings, Inc. - Contents herein do not constitute a warranty.