

ENERGIZER NO. 455

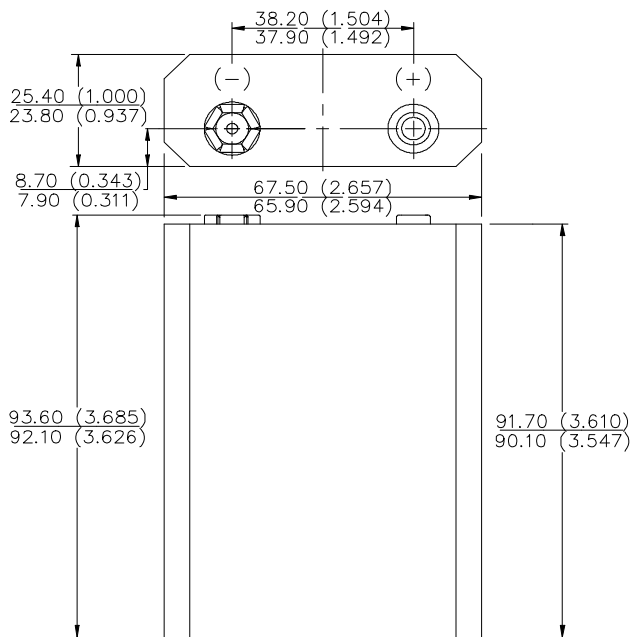

Industry Standard Dimensions in mm (inches)



Chemical System: Zinc-Manganese Dioxide (Zn/MnO₂)

Designation: ANSI / NEDA-202, IEC-30F40

Battery Voltage: 45 Volts

Average Weight: 231 grams (8.2 oz.)

Volume: 157 cubic centimeters (9.6 cubic inch)

Average Capacity: 550 mAh to 0.8 volts/cell
 (Rated at 25 mA continuous drain at 21°C)

Cells: Thirty No. 130 in series

Jacket: Paper

TYPICAL DISCHARGE CURVE

Simulated Test @ 21°C (70°F)

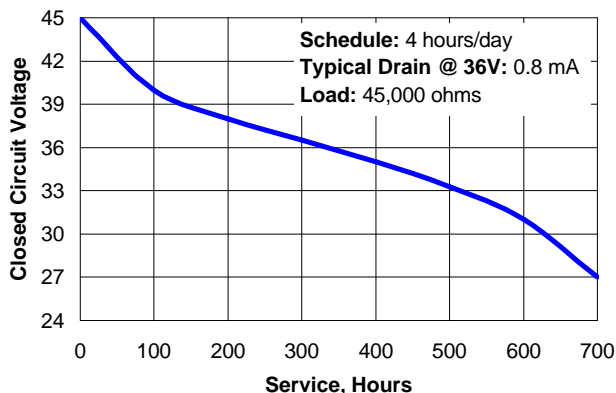

Simulated Application Test Estimated Average Service at 21°C (70°F)

Schedule:	Typical Drains at 36V (milliamperes)	Load (ohms)	Cutoff Voltage					
			24V	27V	30V	33V	36V	39V
4 hours/day	0.8	45,000	695	638	512	350	130	
4 hours/day	7.2	5,000	70	62	52	39	28	12

Important Notice

This data sheet contains information specific to batteries manufactured at the time of its publication.

Contents herein do not constitute a warranty.

Copyright © Eveready Battery Co. Inc. - All Rights Reserved