

ENERGIZER NO. 206

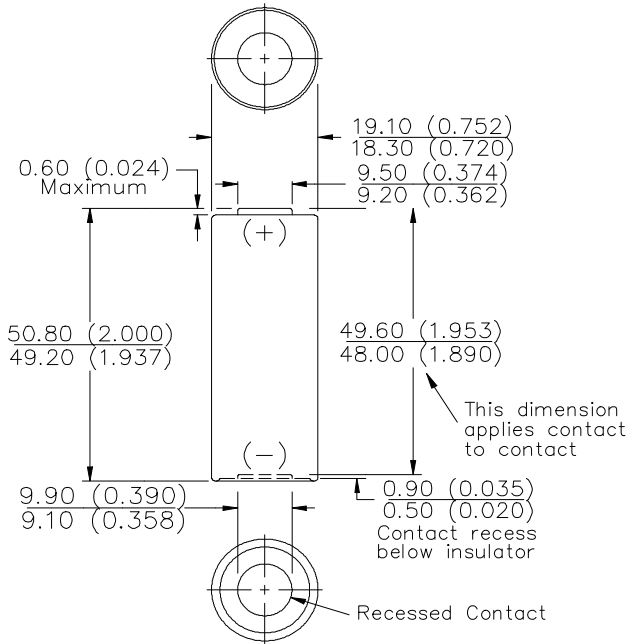

Industry Standard Dimensions in mm (inches)



Chemical System: Zinc-Manganese Dioxide (Zn/MnO₂)

Designation: ANSI / NEDA-1611

Battery Voltage: 9.0 Volts

Average Weight: 32 grams (1.1 oz.)

Volume: 14 cubic centimeters (0.9 cubic inch)

Average Capacity: 200 mAh to 0.8 volts/cell
 (Rated at 25 mA continuous drain at 21°C)

Cells: Six No. 110 in series

Jacket: Metal

TYPICAL DISCHARGE CURVE

Simulated Test @ 21°C (70°F)

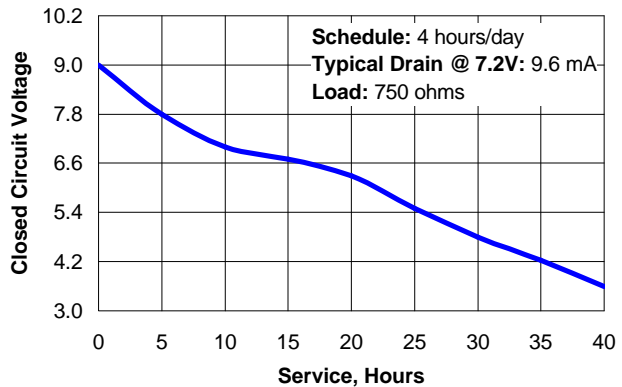

Simulated Application Test Estimated Average Service at 21°C (70°F)

Schedule:	Typical Drains at 7.2V (milliamperes)	Load (ohms)	Cutoff Voltage					
			4.2V	4.8V	5.4V	6.0V	6.6V	7.2V
4 hours/day	9.6	750	35.8	31.0	26.0	21.8	17.4	11.4
4 hours/day	12.9	560	23.9	16.9	14.9	11.7	9.4	5.5

Important Notice

This data sheet contains information specific to batteries manufactured at the time of its publication.

Contents herein do not constitute a warranty.

Copyright © Eveready Battery Co. Inc. - All Rights Reserved